



AI TONG SCHOOL

2025 END-OF-YEAR EXAMINATION

PRIMARY FIVE SCIENCE

(BOOKLET A)

27 OCTOBER 2025

Total time for booklets A and B : 1 h 45 min

INSTRUCTIONS

Do not turn over this page until you are told to do so.

Follow all instructions carefully.

Answer all questions.

Name: _____ ()

Class : Primary 5 _____

Parent's Signature : _____

Booklet A	60
Booklet B	40
Total	100

A-1

Section A (30 x 2 marks)

For each question from 1 to 30, four options are given. One of them is the correct answer. Make your choice and shade the correct oval (1, 2, 3 or 4) on the Optical Answer Sheet.

1. Which of the following organisms is not a fungus?

- (1) fern
- (2) yeast
- (3) mould
- (4) mushroom

2. Study the chart below.

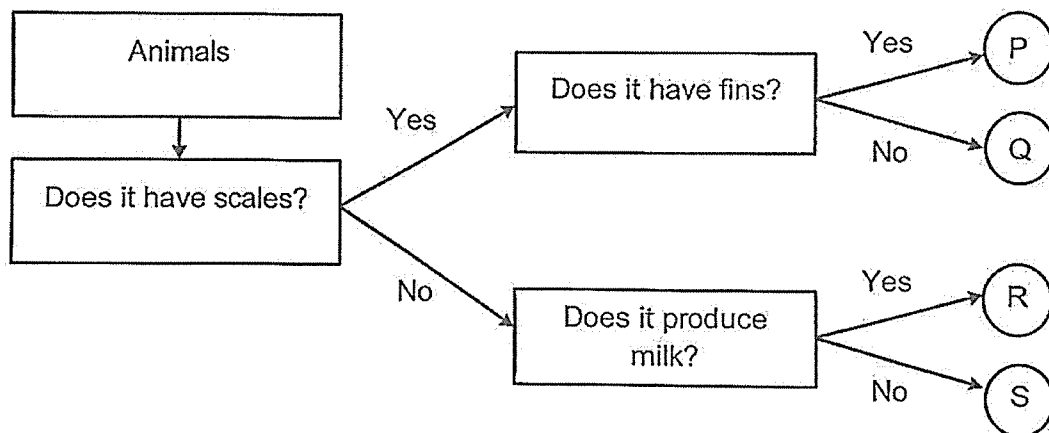

Which of the following is correct?

	Reptile	Fish	Mammal	Bird
(1)	P	Q	R	S
(2)	P	S	Q	R
(3)	Q	P	S	R
(4)	Q	P	R	S

3. The table below compares the life cycles of a butterfly and a mosquito.

	Statement	Butterfly	Mosquito
A	Has four stages in its life cycle	Yes	Yes
B	Lays eggs in water	No	Yes
C	The larva stage of its life cycle is a pest to humans.	No	Yes

Which comparison(s) is/are correct?

- (1) A only
 (2) A and B only
 (3) B and C only
 (4) A, B and C
4. The bar graph below shows the number of days that insects X and Y spend in each stage of their life cycles.

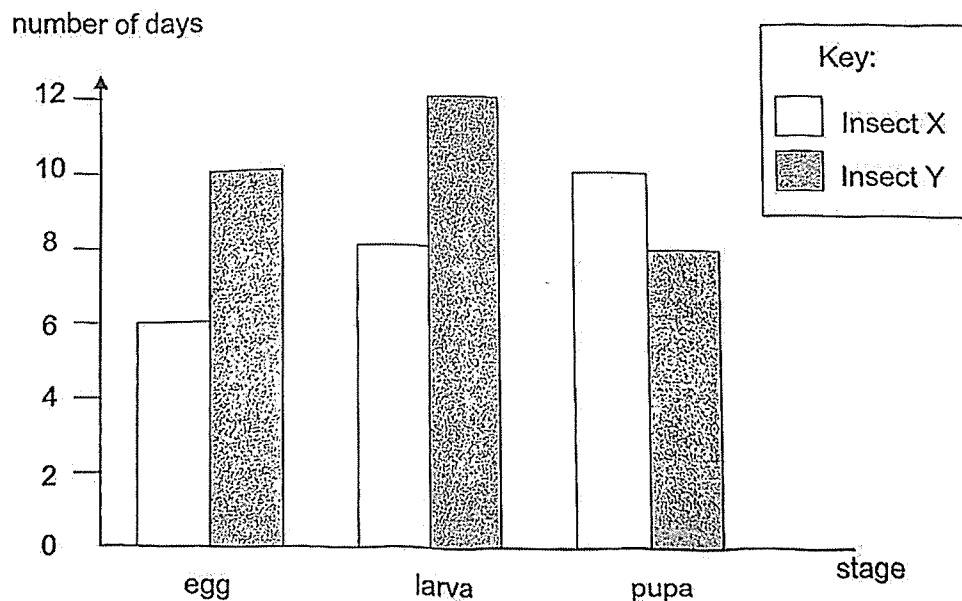

Based on the graph, which statement is correct?

- (1) Insect Y lays more eggs than insect X.
 (2) The egg of insect X takes six days to hatch into a larva.
 (3) 10 days after insect X's egg hatches, it will be in larva stage.
 (4) On the thirteenth day after the egg is laid, insect Y is at its pupa stage

5. The diagram below shows a seed germinating and growing into an adult plant over several weeks.

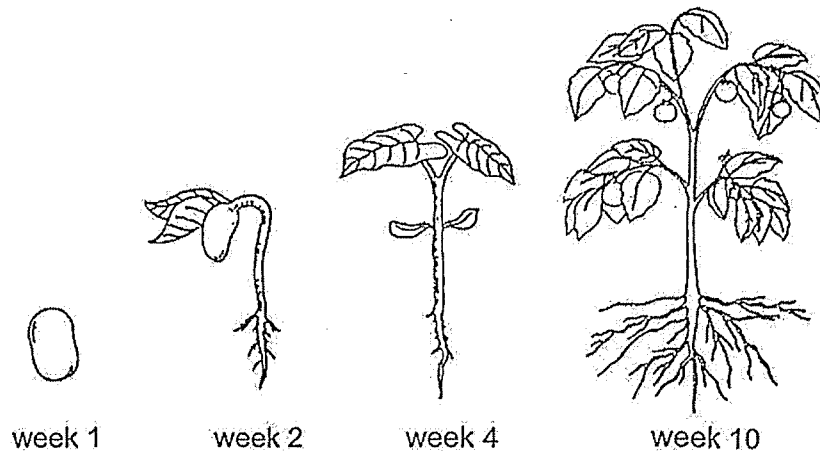

Which of the following statement(s) is/are correct?

- A The plant reached its adult stage at week 4.
- B The plant is able to make its own food at week 1.
- C The fruits in week 10 had developed from the ovaries of the flowers.
- D Air, light and the right temperature are needed for the plant to grow from week 1 to week 2.

- (1) C only
- (2) A and C only
- (3) B and D only
- (4) A, B and D only

6. Which statements about the reproduction of humans are correct?
- A A female parent can pass on characteristics to her male child.
 - B A fertilised egg is formed after an egg fuses with sperms.
 - C Humans can only reproduce after their reproductive parts have matured during puberty.
 - D Fertilisation occurs when the male reproductive cell fused with the female reproductive cell in the ovary.

- (1) A and C only
- (2) B and D only
- (3) A, C and D only
- (4) A, B, C and D

7. The diagram below shows how blood flows in some parts of the human body after a meal.

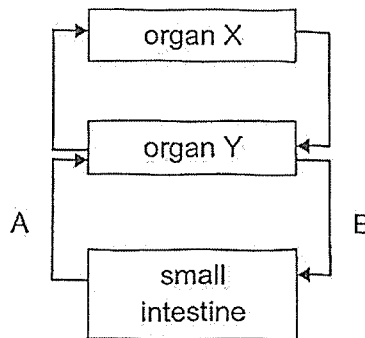

Which of the following best describes the diagram above?

	organ X	organ Y	blood at A compared to blood at B
(1)	heart	lungs	more digested food but less carbon dioxide
(2)	lungs	heart	less digested food but more carbon dioxide
(3)	heart	lungs	less digested food and carbon dioxide
(4)	lungs	heart	more digested food and carbon dioxide.

8. Tessa wanted to find out how the temperature of water affects the rate of movement of water in stems. She used three similar pieces of stem and three identical beakers with the same volume of water. She recorded the volume of water left in the beakers after three hours.

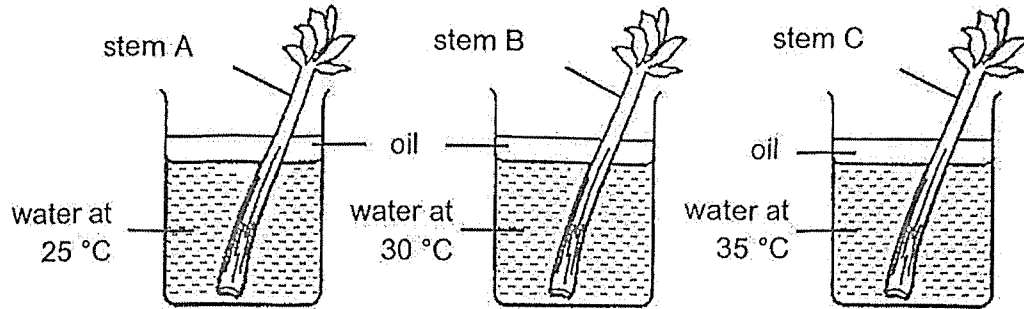

Which of the following variables should be kept constant in the experiment?

- (1) length of stem
 - (2) temperature of water
 - (3) volume of water transported up each piece of stem
 - (4) time taken for the water to reach the top of the stem
9. The graph shows the amount of undigested food in organs A, B and C in the human digestive system.

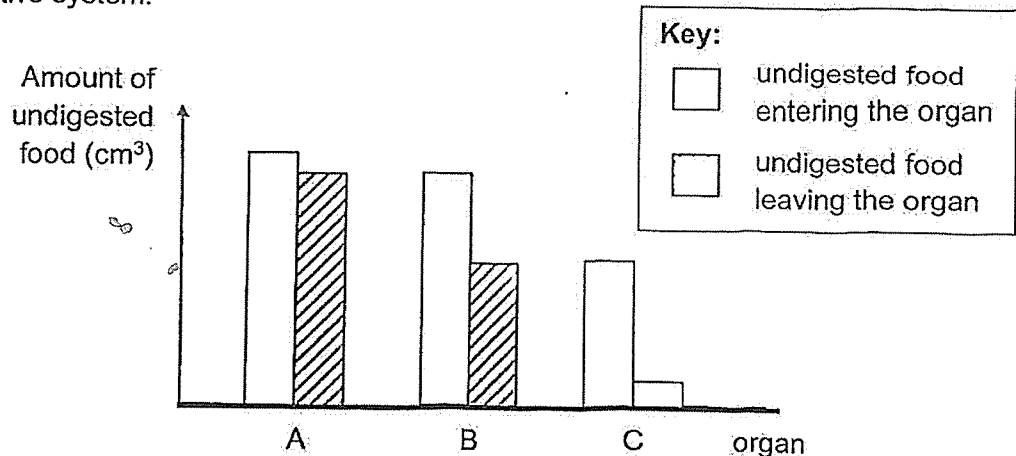

Based on the information above, which of the following statements is correct?

- (1) No digestion occurred in organ C.
- (2) Most food was digested in organ A.
- (3) All the organs, A, B and C, release digestive juices.
- (4) More digested food was absorbed in organ A than in organ B.

10. Two boys were trapped in a lift for several hours without ventilation.

Which statement is correct?

- (1) The temperature of the air in the lift increases after a while.
- (2) There is a greater amount of nitrogen in the lift than before.
- (3) The air contains lesser water vapour as their breathing rate increases.
- (4) There is lesser amount of oxygen and carbon dioxide as they respire more.

11. The diagram below shows part of the respiratory system in a fish and a human.

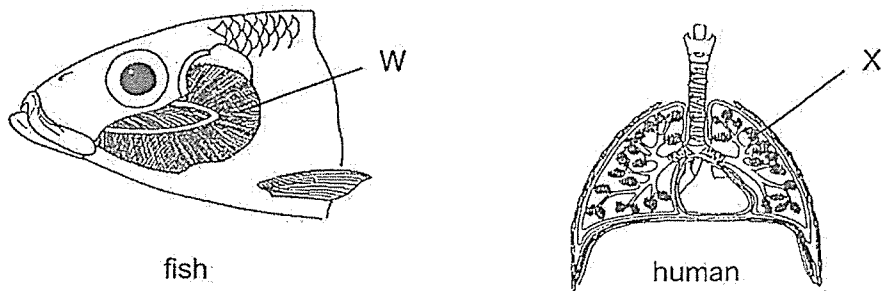

Which statement(s) is/are correct?

- A Blood vessels are found in X, but not in W.
- B W takes in dissolved oxygen in water and pumps it throughout the body.
- C Carbon dioxide moves from the blood to X and leaves the lungs through the windpipe and the nose.

- (1) A only
- (2) C only
- (3) A and C only
- (4) B and C only

12. Javier cut a ring from the stem of a plant. After two days, he observed that the part above the ring appeared swollen.

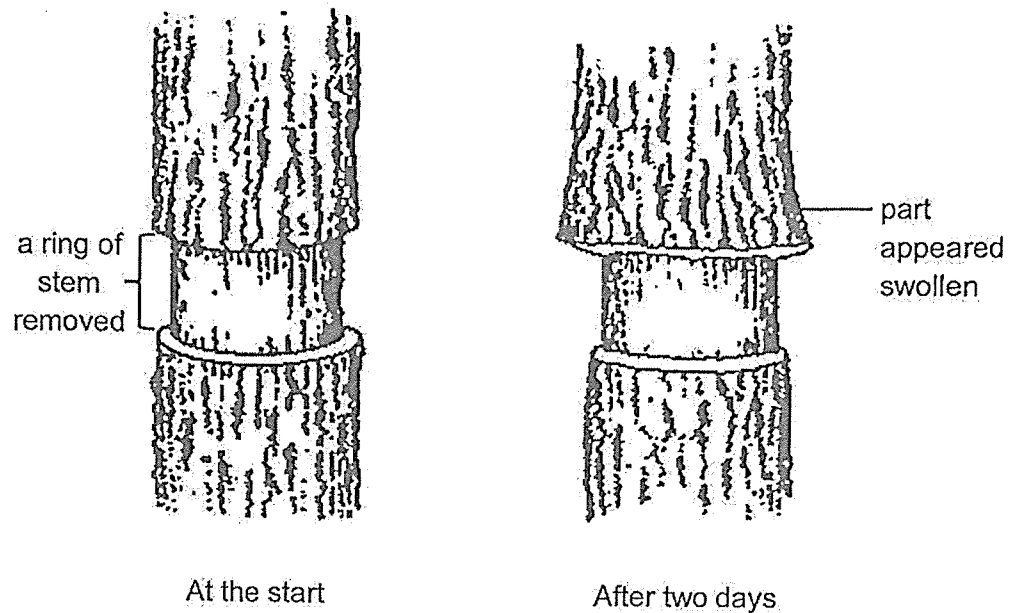

Which of the following best explains why the part above the ring appeared swollen?

- (1) The food-carrying tubes have been removed so the food made from the leaves was not able to travel to the roots.
- (2) The water-carrying tubes have been removed so the water was not able to travel up to the leaves.
- (3) Both the water-carrying and food-carrying tubes have been removed so water and food were not able to travel to the leaves.
- (4) Both the water-carrying and food-carrying tubes have been removed so water and food were not able to travel up to the other parts of the plant.

13. The diagram below shows a beaker filled with two substances, A and B.

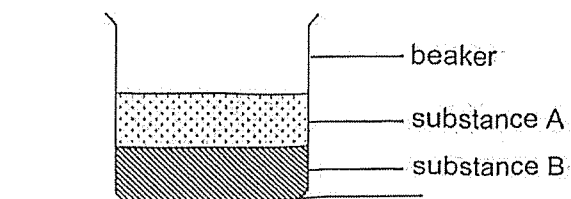

The beaker was then put on a wooden wedge.

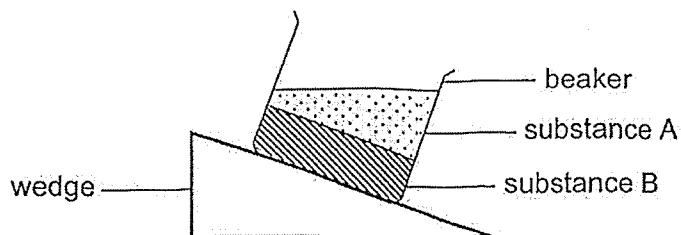

Which states of matter could substances A and B in the beaker be?

	A	B
(1)	gas	solid
(2)	liquid	solid
(3)	gas	liquid
(4)	solid	liquid

14. The table below shows the state of substances, X, Y and Z at different temperatures.

substance	state of substance at		
	0°C	75°C	150°C
X	liquid	liquid	liquid
Y	liquid	liquid	gas
Z	solid	solid	solid

Which of the following statements is correct?

- (1) The melting point of substance X is 0°C.
- (2) The boiling point of substance Y is 150°C.
- (3) Substance Z has the highest melting point.
- (4) Substance X has a lower boiling point than Y.

15. Jacob placed a glass jar with a metal lid in a refrigerator.

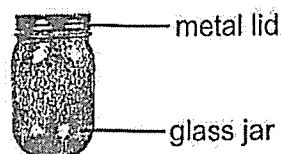

He took out the jar and tried opening it after some time. He failed to unscrew the metal lid from the glass jar.

Which statement explains Jacob's difficulty to open the jar?

- (1) The metal lid lost heat faster to the glass jar and contracted more.
 - (2) The metal lid lost heat faster to the refrigerator and contracted more.
 - (3) The metal lid gained heat faster from the glass jar and contracted more.
 - (4) The metal lid gained heat faster from the refrigerator and contracted more.
16. A loaf of bread takes 40 minutes to be completely baked at 190°C . Sarah bakes a loaf of bread in the oven at 190°C for 10 minutes and inserts a thermometer into the centre of the bread. The reading on the thermometer is 80°C .

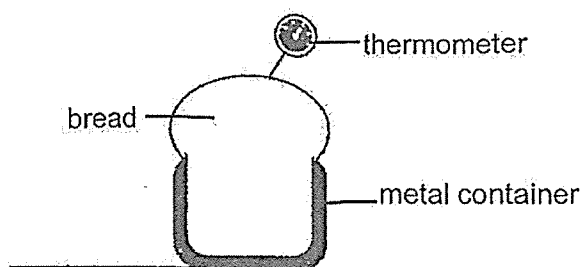

Which of the following explains why the temperature is 80°C after 10 minutes?

- (1) The bread is a poor conductor of heat so heat is conducted slowly from the air in the oven to the bread.
- (2) The bread is a good conductor of heat so heat is conducted quickly from the bread to the air in the oven.
- (3) The metal container is a poor conductor of heat so heat is conducted slowly from the air in the oven to the bread.
- (4) The metal container is a good conductor of heat so heat is conducted quickly from the air in the oven to the bread.

17. Ken tested four different materials, W, X, Y and Z, using the circuit below and observe if the bulb will light up.

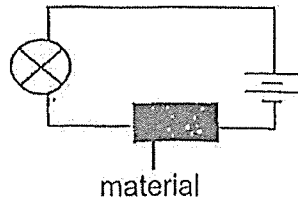

He recorded his observations in the table below.

Material	Did the bulb light up?
W	No
X	Yes
Y	No
Z	Yes

He then used the four materials to make four similar containers. The containers were of the same height and volume. He filled each container with 20°C water and left the containers in a sunny place.

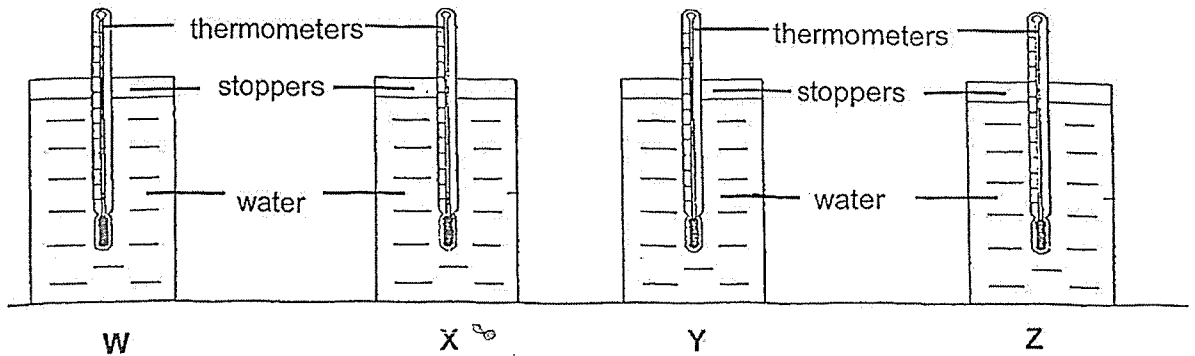

Which of the following is the most likely temperature of water in the four containers, W, X, Y and Z, after 40 minutes?

Temperature of the water (°C)				
	W	X	Y	Z
(1)	30	32	23	24
(2)	32	24	30	23
(3)	23	24	30	32
(4)	23	30	24	32

18. The diagram shows the changes of states of water.

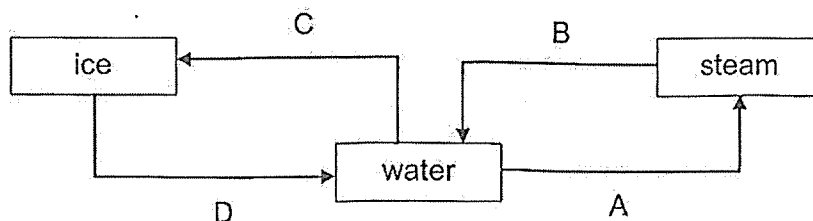

Which processes represent heat loss or heat gain?

	Heat loss	Heat gain
(1)	A and B	C and D
(2)	B and D	A and C
(3)	B and C	A and D
(4)	C and D	A and B

19. The diagram below shows the water cycle.

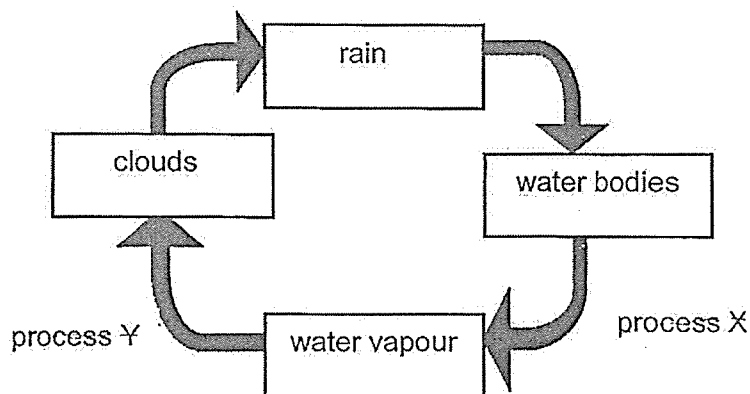

Which statements correctly describe how processes, X and Y, would be affected if there is less heat in the surrounding?

- A Process X would happen at a slower rate.
- B Process X would happen at a faster rate.
- C Process Y would happen at a slower rate.
- D Process Y would happen at a faster rate.

- (1) A and C only
- (2) A and D only
- (3) B and C only
- (4) B and D only

20. Nicky went for a swim. After he came out of the swimming pool, he started to shiver. When the wind blew, he felt even colder.

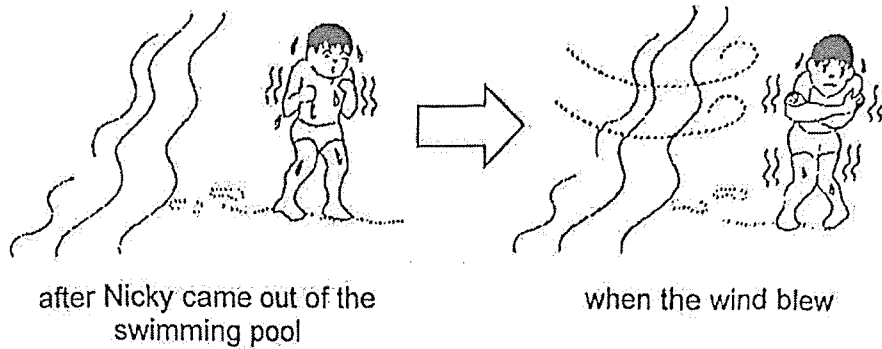

Which statements explain why he felt even colder?

- A The wind transfer coldness to Nicky's body.
- B The water on Nicky's body gained more heat from his body.
- C The water on Nicky's body lost more heat to the surroundings.
- D The wind increased the rate of evaporation of the water on his body.

- (1) A and B only
- (2) B and C only
- (3) B and D only
- (4) A and D only

21. Which of the following actions does not help to conserve water?

- (1) Taking short showers.
- (2) Using a bucket and cloth for washing cars.
- (3) Leaving the water tap on while brushing teeth.
- (4) Using water from the washing machine to mop the floor.

22. Sharon placed four solids made of materials P, Q, R and S into a container of water. Her observation is shown below.

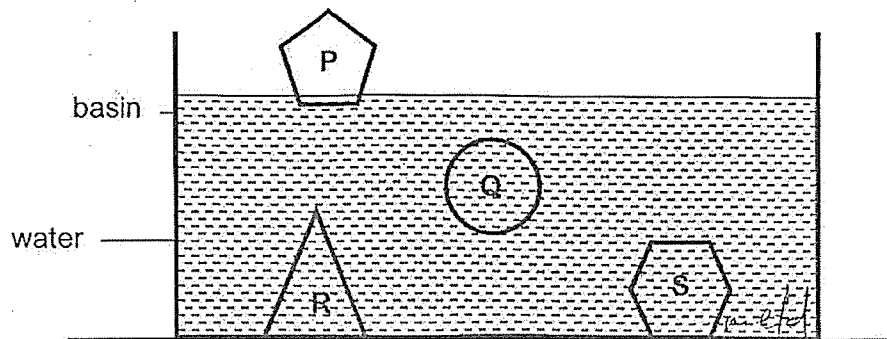

She made three statements:

- A R and S are the same material.
- B P and S are different materials.
- C Q and R are the same material but Q has smaller mass.

Which statement(s) can be concluded from her observation?

- (1) A only
- (2) B only
- (3) A and B only
- (4) A and C only

23. Zi Wen wanted to find out the strength of four different types of materials, W, X, Y and Z. He set up the experiment as shown in the diagram below. The materials are of the same length and thickness.

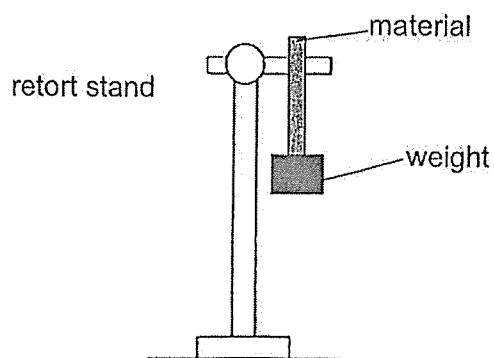

He hung weights on each material till it broke. He concluded that:

- Material Y is stronger than material X.
- Material Z is the weakest and material W is the strongest.

Based on his conclusion, which one of the following sets of results shows the possible amount of weight hung on each material before it broke?

Amount of weight hung on each material (g)				
	W	X	Y	Z
(1)	50	70	100	120
(2)	50	100	70	120
(3)	120	100	70	50
(4)	120	70	100	50

24. The diagram below shows four closed circuits with identical working bulbs and batteries.

circuit M

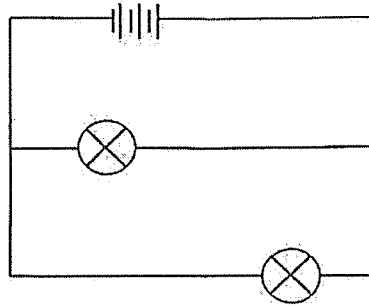

circuit N

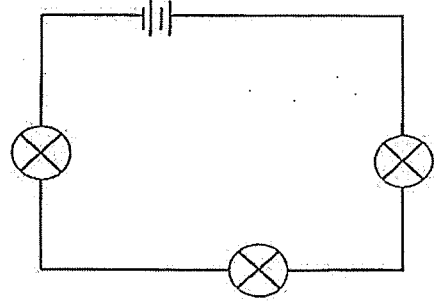

circuit O

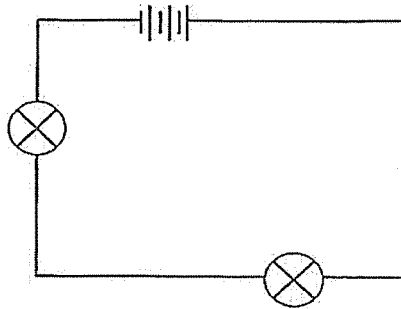

circuit P

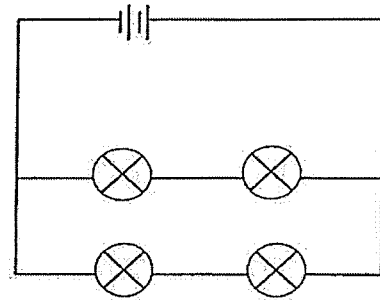

Which of the following correctly arranges the bulbs in each circuit from the brightest to the dimmest?

- (1) M, O, P, N
 (2) N, P, O, M
 (3) O, M, P, N
 (4) O, M, N, P

25. Study the following circuits.
In which of the following circuits will the light bulb light up?

(1)

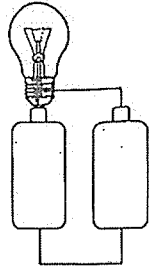

(2)

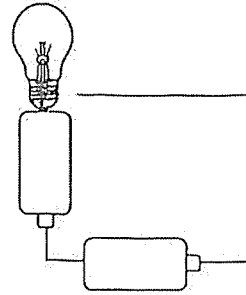

(3)

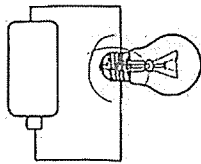

(4)

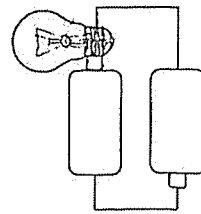

26. The diagram shows five identical bulbs connected to two batteries.

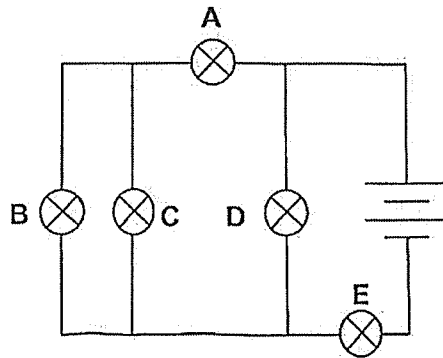

All five bulbs lit up initially. When one of the bulbs was removed from the circuit, it was observed that only two bulbs lit up.

Which two bulbs would continue to light up?

- (1) A and B
- (2) B and C
- (3) C and D
- (4) D and E

27. The circuit board shown below has a metal pin at each of the points A to E. The pins are connected by electrical wires.

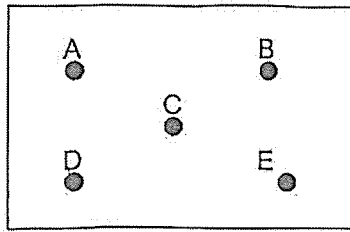

circuit board

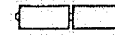

circuit tester

The ends of a circuit tester are connected to different pairs of pins on the circuit board and the results are shown in the table below.

Pins connected to the circuit tester	Does the bulb light up?
A and B	No
C and D	Yes
A and D	Yes
B and E	No

Based on the results shown in the table above, which of the following drawings shows the correct arrangements of wires in the circuit board?

(1)

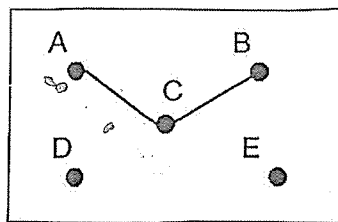

(2)

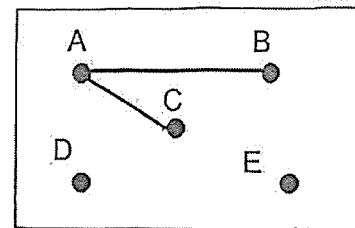

(3)

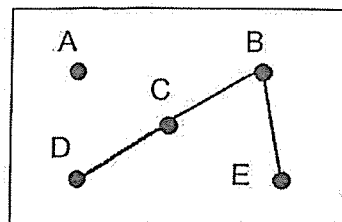

(4)

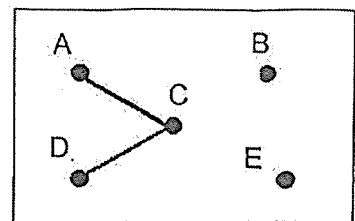

28. Maria carried out an experiment in a dark room as shown in the diagram below.

She cut a triangular hole on sheet X. She then arranged sheets W, X, Y and Z in a straight line. When Maria switched on the torch, a bright triangular patch of light was shown on sheet Y only.

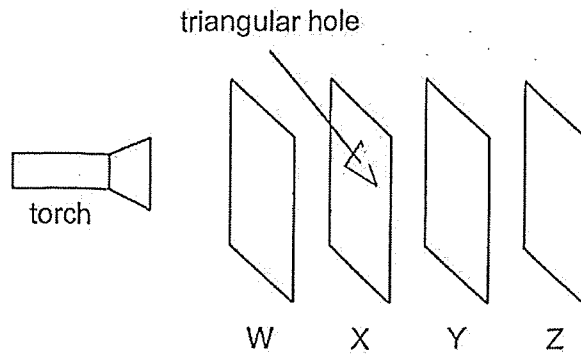

Which of the following correctly describes the properties of the materials that sheets W, X, Y and Z are made of?

	Allows light to pass through	Does not allow light to pass through	Not possible to determine
(1)	W	X and Y	Z
(2)	X	W and Y	-
(3)	W	X	Y
(4)	W	Y	X

29. Caden set up two similar closed circuits connected to an iron rod. The diagram below shows what happens when two bar magnets are brought close to each iron rod. J, K, L and M are poles on the magnets.

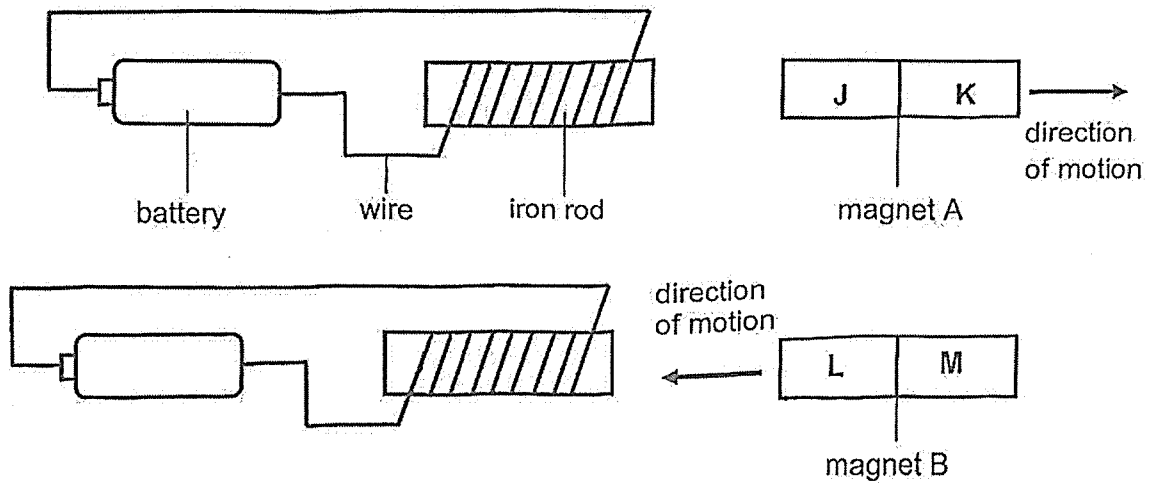

Based on the above results, what would be a possible arrangement if magnets A and B are placed together?

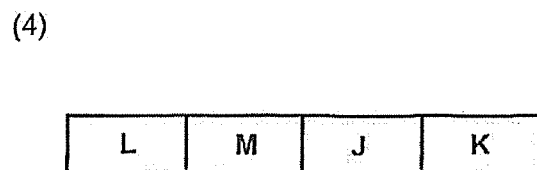
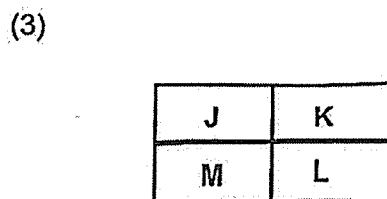
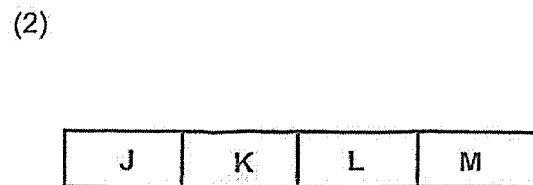
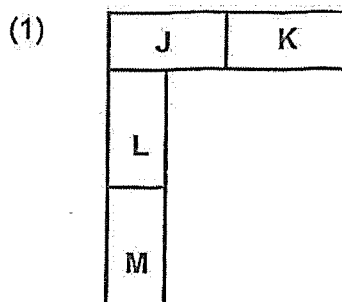

30. Object P was brought near both poles of a freely suspended magnet.

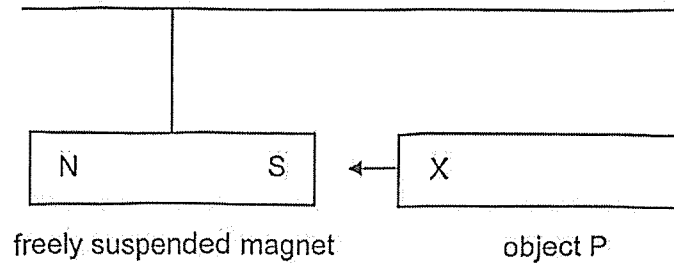

The experiment was repeated with objects Q, R and S. The observations are recorded in the table below.

Object	When X was brought near the North pole of the magnet	When X was brought near the South pole of the magnet
P	did not attract or repel	did not attract or repel
Q	Attracted	Attracted
R	Repelled	Attracted
S	Attracted	Attracted

Three statements were made by a student based on the observations.

- A Objects P, Q and S are not magnets.
- B Objects Q and S are magnetic materials and object R is a magnet.
- C Object P is a magnetic material and objects Q, R and S are magnets.

Which statement(s) is/are correct?

- (1) A only
- (2) B only
- (3) A and B only
- (4) B and C only

~ End of Booklet A ~



AI TONG SCHOOL

**2025 END-OF-YEAR EXAMINATION
PRIMARY FIVE SCIENCE**

(BOOKLET B)

27 OCTOBER 2025

Total time for booklets A and B : 1 h 45 min

INSTRUCTIONS

Do not turn over this page until you are told to do so.

Follow all instructions carefully.

Answer all questions.

Write your answers in this booklet.

Name : _____ ()

Class : Primary 5 _____

Parent's Signature : _____

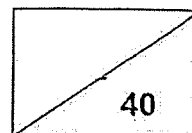

Section B: 40 marks

For questions 31 to 41, write your answers in the spaces provided. The number of marks available is shown in brackets [] at the end of each question or part question.

31. The diagram below shows two flowers, G and H.

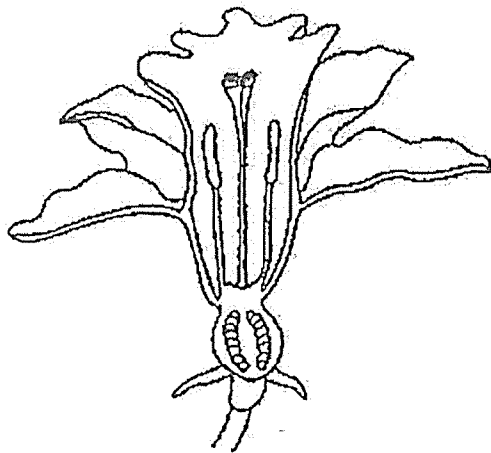

flower G

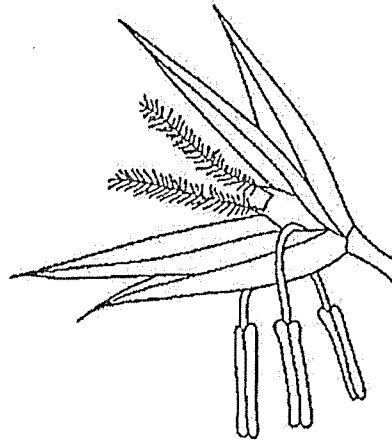

flower H

- (a) Draw one arrow in flower G to show the process of pollination. [1]
- (b) Based on the diagram, which flower, G or H, is pollinated by wind? Explain your answer. [2]

- (c) Name the process that occurs after pollination has taken place. [1]

(Go on to the next page)

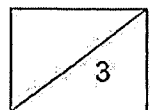

32. Nick carried out an experiment to find out the rate of reproduction of bacteria X at different temperatures. He used the same amount of bacteria X for the various temperatures at the start of the experiment. After 24 hours, his results are as shown below.

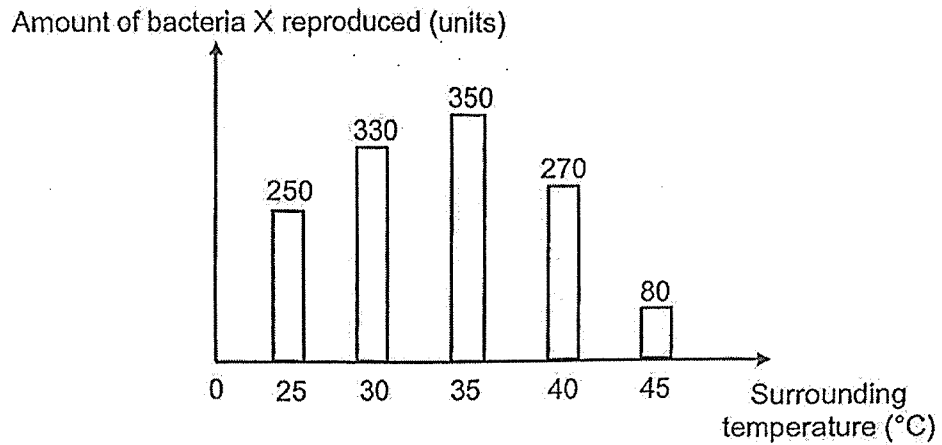

- (a) Explain why he used the same amount of bacteria X at the start of the experiment. [1]

- (b) Bacteria is found in raw food.

Based on the information provided, what is the surrounding temperature that causes raw food to turn bad most quickly? Explain your answer. [1]

Question 32 continues on the next page.

(Go on to the next page)

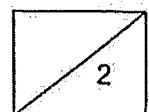

Question 32 continues on this page.

Next, Nick conducted another experiment to find out if bacteria X can be killed at high temperatures. He heated the same amount of bacteria X at different temperatures for 15 seconds. His results are shown below.

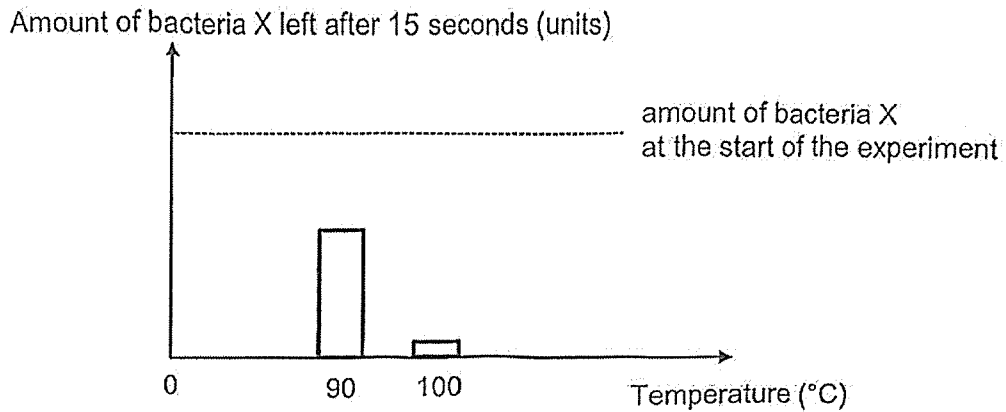

- (c) Nick cooked some raw food to 100°C for 15 seconds. Based on the graph above, explain why the cooked food may not be safe to eat even though it was heated to a high temperature. [1]

In order to preserve the raw food longer, Nick vacuum sealed it by removing air from the airtight bag as shown in the diagram below.

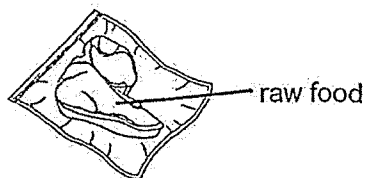

- (d) Using the characteristic of living things, explain how Nick's method helps to preserve raw food longer. [1]

(Go on to the next page)

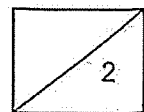

33. (a) Complete the diagram below by drawing two more arrows to show how food is transported in the plant. [1]

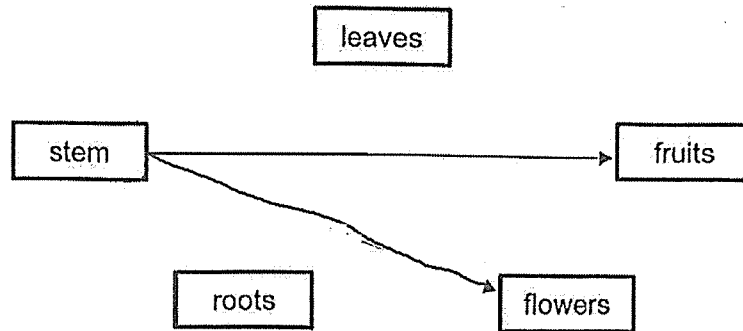

- (b) The diagram below shows a plant with leaves A, B and C and parts of the stem removed at positions X and Y. The gardener cut the end of the stem at an angle before placing it in water.

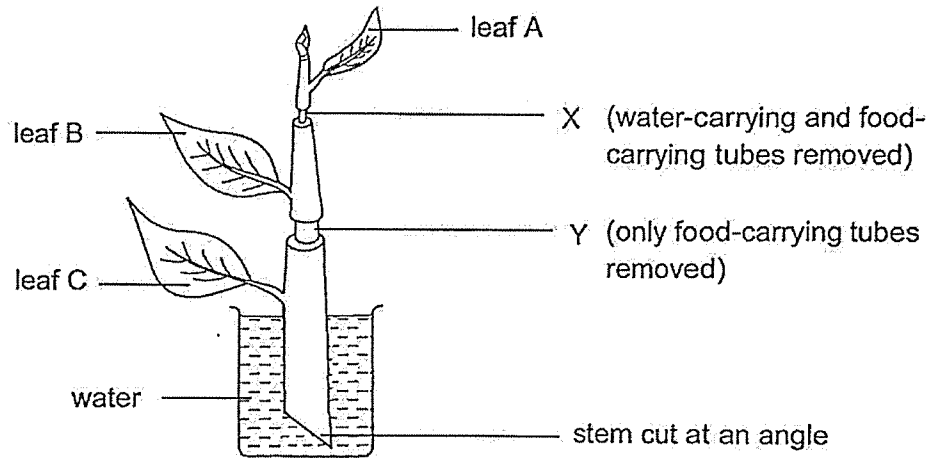

- (i) Which leaf, A, B or C, will wilt first? Explain your answer. [1]

- (ii) Why do the gardener cut the stem of the plant at an angle before putting it in water? [1]

(Go on to the next page)

34. Sufen went to a park to exercise. She started with a slow walk. Then, at point K, she started running for a while before she took a rest.

The graph below shows the change in Sufen's heart rate over the period of time.

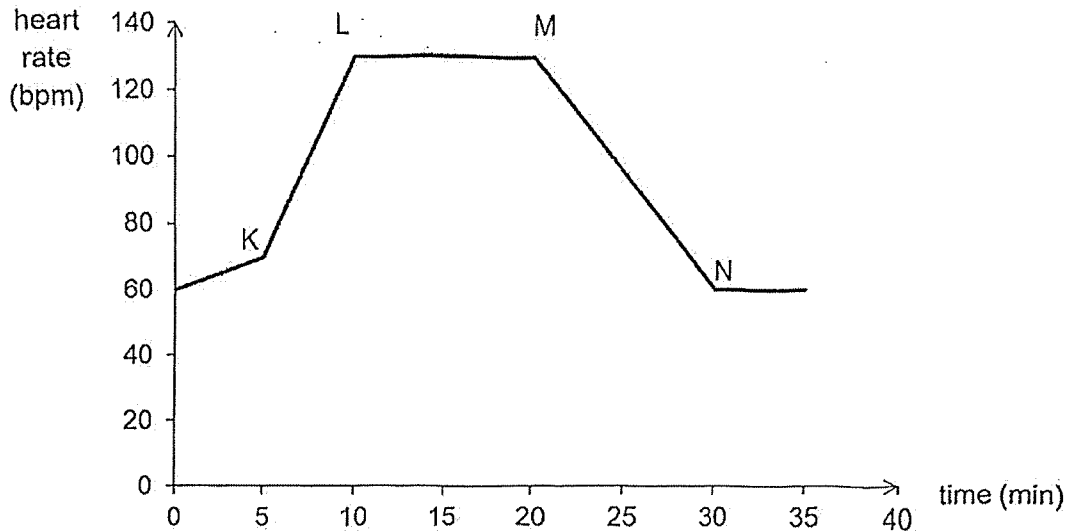

- (a) At which point (K, L, M or N) on the graph did Su Fen stop to rest? [1]

Point: _____

- (b) Explain why Sufen's heart rate changed from Point K to L. [2]

(Go on to the next page)

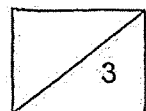

35. Leaves have tiny openings on their surfaces. Sean studied the surfaces of a leaf from a plant under a microscope. He noticed that the tiny openings are on both surfaces of the leaf.

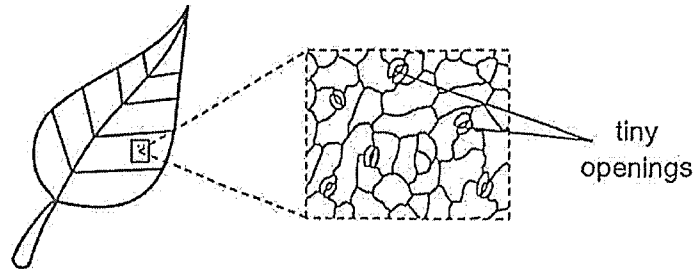

- (a) What is the main function of the tiny openings? [1]

Sean also measured the changes in the size of the tiny openings of the plant placed in a sunny place at different times of the day. The results are shown in the table below.

Time	6am	8am	10am	12pm	2pm	4pm	6pm
Amount of sunlight (units)	1	6	10	13	11	8	4
Average size of the tiny openings (units)	1	3	5	8	5	3	1

- (b) What is the relationship between the size of the tiny openings and the amount of sunlight? [1]

Question 35 continues on the next page.

(Go on to the next page)

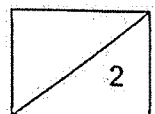

Question 35 continues on this page.

Sean then placed three similar plants in beakers A, B and C. The leaves of these plants have more tiny openings on their underside than on their upper side.

The beakers were filled with the same amount of water and placed near the window for two days.

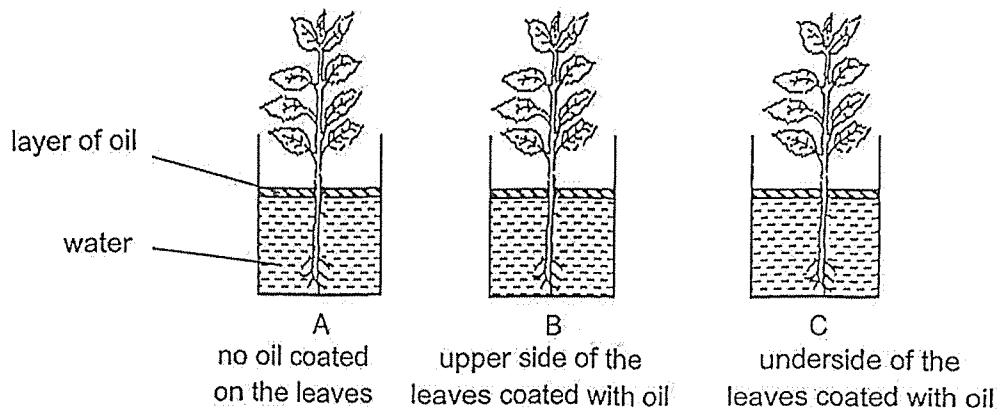

After two days, Sean measured the amount of water left in the three beakers. The results are recorded in the table below.

Beaker	Amount of water left in the beaker at the end of the experiment (ml)
A	100
B	150
C	170

(c) What is the purpose of having a layer of oil? [1]

(d) Explain why there is more water left in beaker C than in beaker B. [1]

(Go on to the next page)

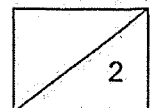

36. (a) State one similarity between evaporation and boiling. [1]

Carrie observed some "white clouds" near the spout of the kettle when the water was boiling.

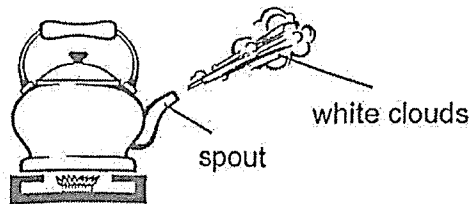

- (b) Name the state of matter of the "white clouds". [1]

Hot air escapes from the airplanes as they fly high in the sky. During an air show, Carrie observed some trails of "white clouds" left behind the airplanes. These "white clouds" were similar to the one she observed near the spout of the kettle.

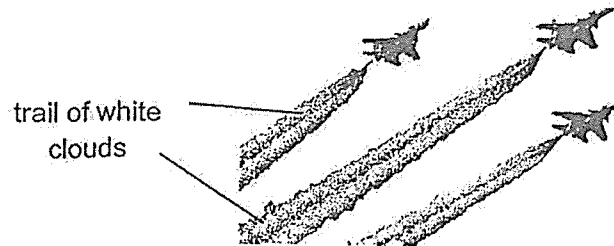

- (c) Describe how the trails of "white clouds" were formed. [2]

- (d) Carrie observed that the trails of "white clouds" disappeared after some time. Explain what happened to the "white clouds". [1]

(Go on to the next page)

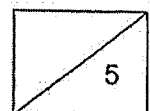

37. Timothy fully submerged a toy water gun in a basin of water as shown in diagram 1. In diagram 2, he opened the cap and observed that water from the basin started to flow into the tank of the water gun.

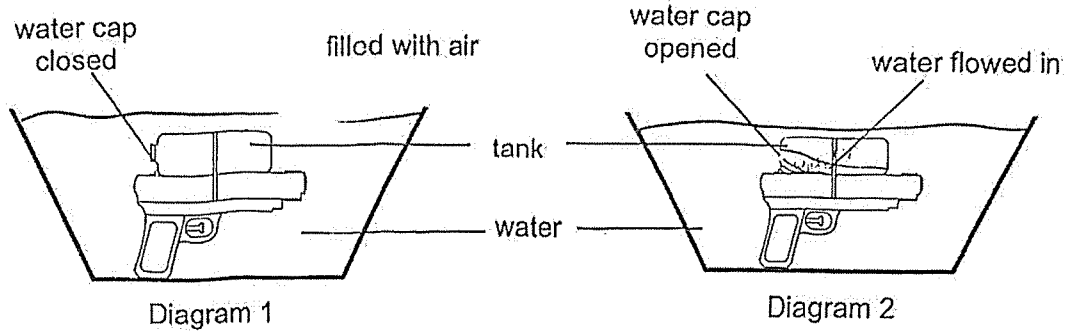

- (a) Explain why the water can flow into the tank of the water gun. [1]

Timothy then filled a water container with 3000 cm^3 of water. He pumped in 1000 cm^3 of air into the container before he pressed the water tap, allowing 500 cm^3 of water to flow out.

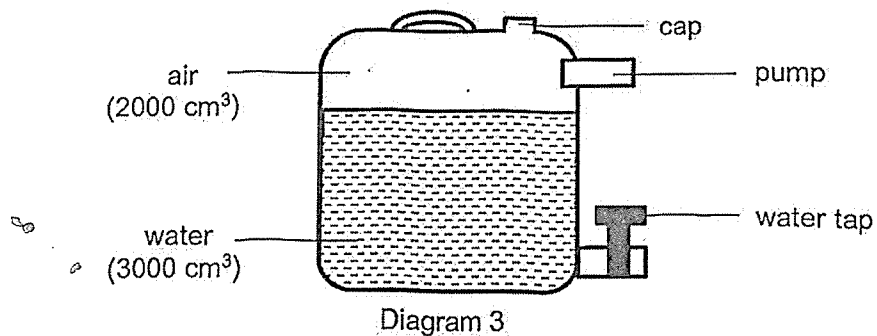

- (b) What is the final volume of air in the container? [1]

- (c) Based on (b), state one property of air. [1]

(Go on to the next page)

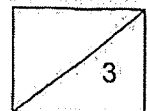

38. James has a toy with plastic frogs and magnets. Each frog has a hole for rod P to slot through.

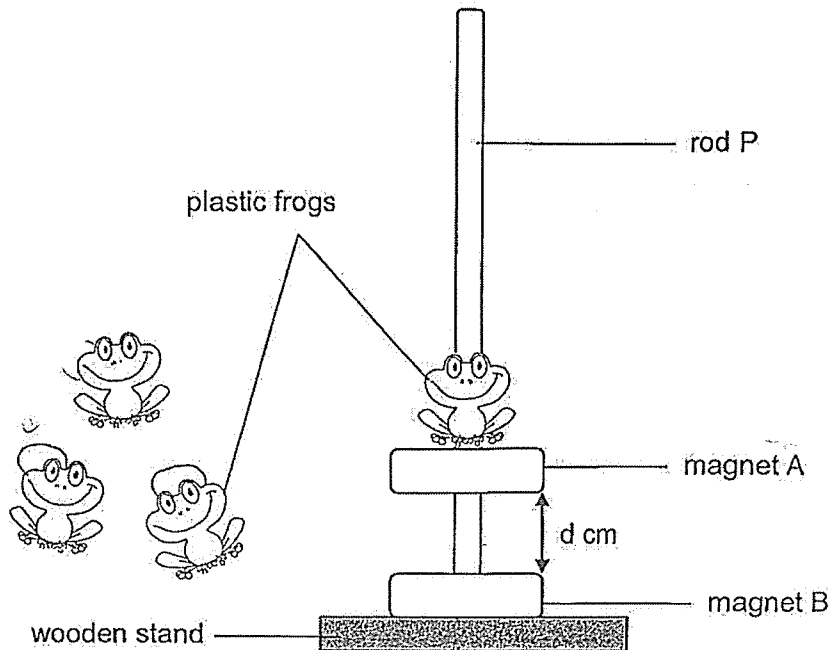

When James pushes magnet A with the frog downwards towards magnet B and releases it, magnet A will bounce back upwards and remain at the position as shown above.

- (a) Name an example of a material used to make rod P for the toy to work. [1]

- (b) Explain why magnet A is at the position as shown in the diagram. [1]

Question 38 continues on the next page.

(Go on to the next page)

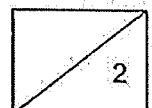

Question 38 continues on this page.

James wanted to investigate how the number of frogs he adds to the toy affects the distance, d , between magnet A and magnet B.

Number of frogs added	Distance d between magnet A and magnet B (cm)
1	3.0
2	2.5
3	?
4	1.5

- (c) Based on the results in the table above, predict the distance d between magnet A and magnet B when three frogs were added on top of magnet A. [1]

Distance: _____

- (d) State one variable that need to be kept constant to ensure a fair test. [1]
-

(Go on to the next page)

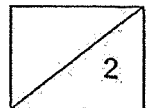

39. Kayden built a toy train which lights up when he pushes it through a tunnel.

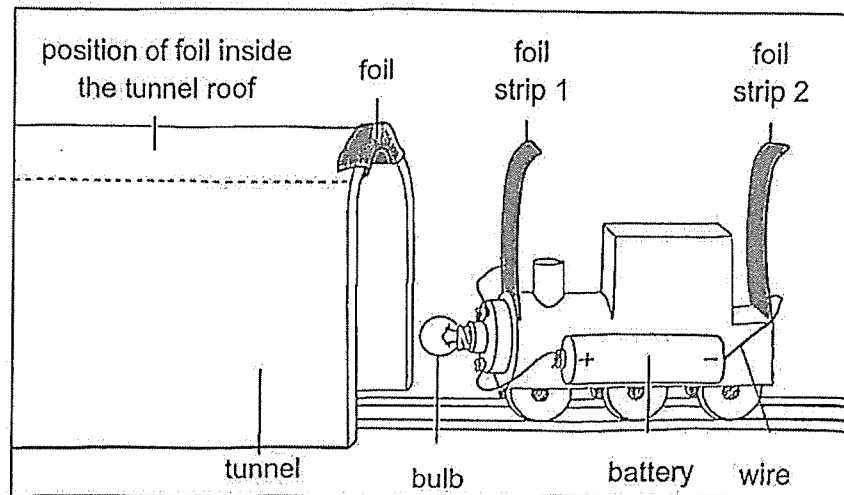

- (a) State a property of the foil which enabled the bulb to light up. [1]

- (b) Explain why the bulb only lights up when the whole train has completely entered the tunnel. [1]

Question 39 continues on the next page.

(Go on to the next page)

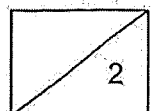

Question 39 continues on this page.

Kayden wants to improve the toy so that the bulb lights up faster when the train enters the tunnel.

- (c) On the diagram below, draw a wire and foil strip 2 to show how he can make the bulb light up faster. [2]

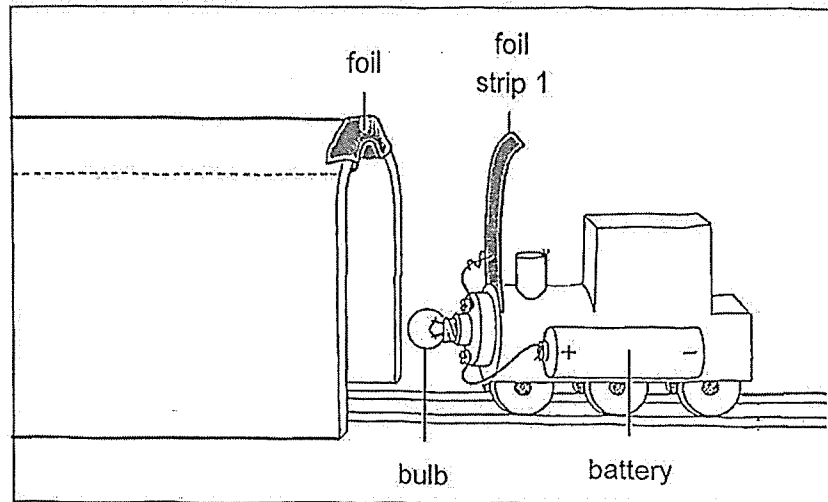

Kayden added three more batteries to the toy train as he wanted the bulb to light up more brightly. However, when the train entered the tunnel, he noticed that the bulb lit up very briefly and then the light went off.

- (d) Suggest one possible reason why the bulb did not continue to light up. [1]

(Go on to the next page)

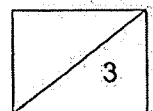

40. Chris conducted an experiment as shown below by pouring 100 ml of water into three identical beakers. He placed each beaker of water on a different material. The set-ups were then heated over a hot plate.

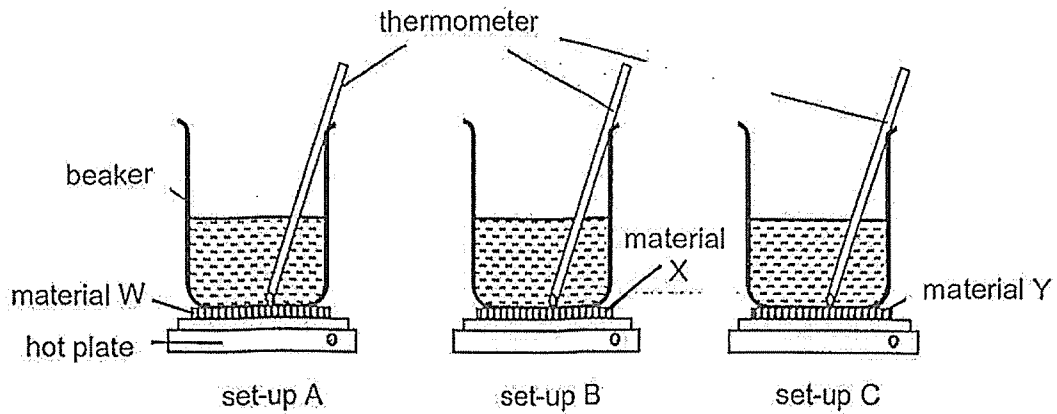

He heated the set-ups for 30 minutes and recorded the temperature of the water in the beakers. The results were shown in the graph below.

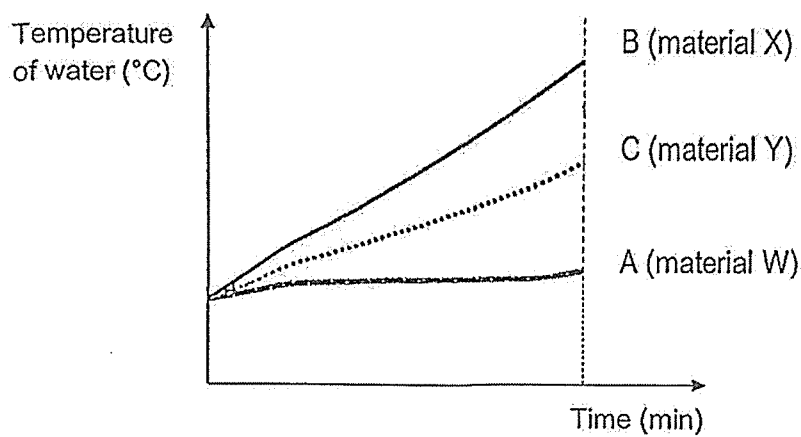

- (a) Based on the results, what was the aim of Chris' experiment? [1]

(Go on to the next page)

Question 40 continues on the next page.

B-14

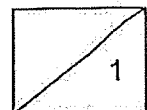

Question 40 continues on this page.

The diagram below shows a cooking pot.

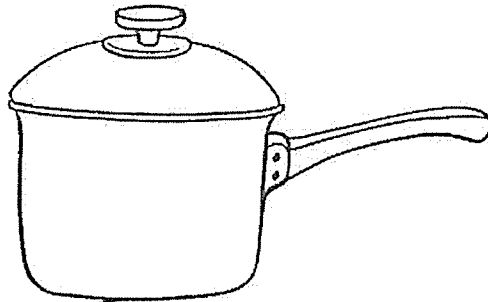

base of cooking pot

- (b) Based on the results, which material, W, X or Y is the most suitable to be used to make the base of the cooking pot? Give a reason for your choice. [1]

(Go on to the next page)

B-15

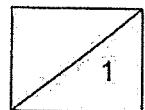

41. Ryan wanted to conduct an experiment to find out if the arrangement of light bulbs would affect the brightness of the light bulbs in an electrical circuit.

- (a) Using circuit symbols, draw two electrical circuits in the boxes below to show how he should set up his circuits to carry out a fair test. Each circuit should consist of wires, two batteries and two light bulbs. [2]

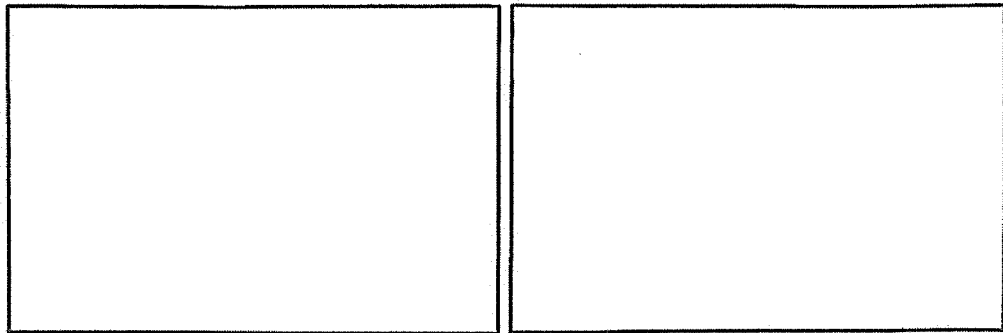

Set-up 1

Set-up 2

- (b) Suggest one way Ryan can make the light bulbs brighter in both circuits. [1]



~ End of Booklet B ~

Please check your work carefully.

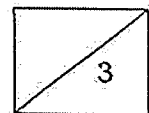

Corrections for Prelim Science 2025
Booklet B

Name: _____ ()

Date: _____

Class: P5 _____

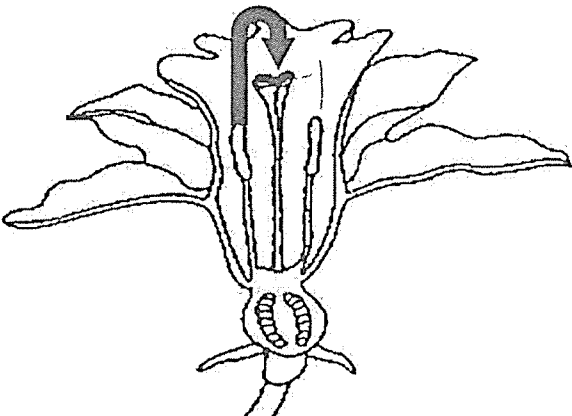
Qn	Answer	Remarks
31. (a)		Refer to TB Pg 15
(b)	<p>Choice: Flower H</p> <p>Data: Flower H has a <u>feathery</u> stigma sticking out.</p> <p>Anthers are protruding out of the flower.</p> <p>Explain: Stigma receives the <u>pollen grains</u> from the <u>anthers</u> more easily.</p> <p>Anther allows pollen grains to be blown by the wind more easily.</p>	
(c)	Fertilisation	
32 (a)	To ensure that there is only one changed variable, which is the <u>surrounding temperature</u> .	Not accepted: - To carry out a fair test - To have one changed variable
(b)	<p>Choice: 35°C</p> <p>Data: Bacteria reproduced the <u>most</u>.</p>	Not accepted: - Wrong or no unit - Grows best
(c)	The cooked food at 100 °C still contains some <u>bacteria X</u> .	

(d)	The bacteria cannot survive without oxygen .	
33(a)	<pre> graph LR stem[stem] --> leaves[leaves] stem --> fruits[fruits] stem --> roots[roots] stem --> flowers[flowers] </pre>	
33(bi)	Leaf A. Water (and mineral salts) cannot be transported past X.	
33(bii)	This is to increase the exposed surface area to absorb more water.	Not accepted: Transport more water
34(a)	Point M	
34(b)	Point 1: Rani needs more energy . Point 2: her heart needs to pump faster (to transport more blood). Point 3: more oxygen and digested food . Point 4: and remove waste materials .	Not accepted: – Heart pump more energy – Transport more digested food and oxygen out of the body – Pump out carbon dioxide
35(a)	To allow oxygen and carbon dioxide to enter or leave. Allows gaseous exchange.	Not accepted: Take in oxygen/carbon dioxide and give out carbon dioxide/oxygen
35(b)	As the amount of sunlight increases , the size of the tiny openings increases .	

(c)	To prevent water in the beaker from evaporate .	
(d)	Less water vapour will escape from plant in beaker C. / The plant made less food .	
36(a)	Both involve heat gain .	
36(b)	Liquid	
36(c)	warmer water vapour from the plane touches the cooler surrounding air , loses heat and condenses into tiny water droplets.	Not accepted: – Source of water vapour not stated – Source of water vapour wrongly stated
36(d)	The water droplets gained heat and evaporated .	Not accepted: Water droplets evaporated
37(a)	Air in the tank escaped the tank through the opening. Water enters the opening to occupy the space previously occupied by air.	
37(b)	2500 cm³	Note: Must state units
37(c)	Air has no definite volume .	
38(a)	Wood / plastic / glass (Any non-magnetic material) Wood	
38(b)	The like poles of magnet A and magnet B are facing each other, and they repel .	

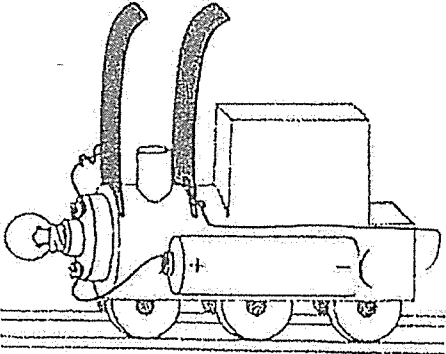
(c)	Any value between 1.6 cm to 2.4 cm	Note: Must state units
(d)	Mass/Weight/size of the frog/ type of frog/ type of magnet	
39 (a)	<u>electrical</u> conductor	
(b)	When the whole train enters the tunnel, both metal strips touches the metal piece on the tunnel to form a <u>closes circuit</u> . This allows electric current to flow through (the bulb) as there is no gap, causing it to light up.	
(c)		
(d)	Too much <u>electric current</u> flowed through the circuit and the bulb has fused.	
40 (a)	To find out if the type of <u>material</u> affect <u>temperature</u> of <u>water</u> .	

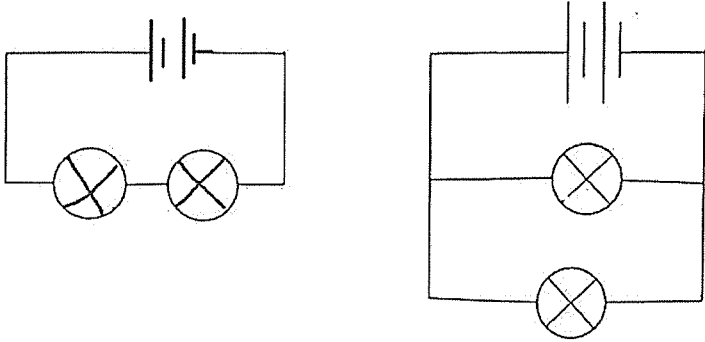
(b)	<p>Choice: X / Set-up B</p> <p>Data (on water): The increase in temperature of <u>water</u></p> <p>is the <u>most</u> for material X.</p> <p>Explain (on material): X is the <u>best</u> conductor of <u>heat</u>.</p>	
41 (a)		
(b)	Add (more) <u>batteries</u>	

